

Design Plans for the "Advantage 6000 Gallon Koi Pond"

Introduction

Today there is a serious problem when it comes to designing and building a quality koi pond. The problem is that few people can agree on how to do it. Most people who decide to build a koi pond start out very excited and determined to build it right the first time; then the problem starts. When they start researching and asking their friends for advice they soon get overwhelmed with conflicting advice. Much of the advice comes from individuals who, though meaning well, have limited experience in building a quality koi pond. They may have built a pond that turned out very successful but unless you build a pond exactly the same size and shape, what worked for them may not work for you.

For a koi pond to really be successful it needs to meet two basic requirements. First, it needs to provide excellent water quality. Not just clear water, but water that is healthy for the fish to live in. Without healthy water your koi experience could be one of constantly treating sick koi. Secondly, a successful koi pond should be easy to maintain. Many ponds, due to poor design, are extremely difficult to take care of.

The "Advantage Koi Pond System" was developed to solve this problem. Each of the five pond designs were developed to basically take all the guess work out of building a "quality" koi pond. Each size pond is designed after a pond that has already been built, tested and refined so that we can guarantee that if you follow the plans closely you will end up with a "successful pond". That is, a pond that will give you excellent water quality and will be the easiest pond to maintain possible.

Each pond in this series has it's own requirements based on the size of the pond. Do not vary too much from the design. Before making any serious changes, please check with your dealer first.

Thank you,

Sacramento Koi



Items Included in this Kit

- 1 - Advantage 10 Bead Filter complete with blower and beads
- 1 - Advantage Bead Filter Operation Instructions
- 2 - 1/4 hp Pumps
- 1 - Emperor Aquatics 130 watt Ultraviolet Light
- 1 - Skimmer 2"
- 1 - Automatic Filler
- 1 - Check Valve 2"
- 2 - Bottom Drain 3"
- 1 - 3 Way Valves 2"
- 5 - Jets with Elbows
- 1 - 2 inch Ball Valve Assembly
- 2 - 3 Inch Clean Out w/ Reducer
- 1 - Can of ABS to PVC Cement
- 1 - Set of Design Plans

Optional Equipment

- Advantage 10 Glass Filter
- Upgrade to Advantage 15 Bead Filter / Glass Filter
- Digital Flow Meter
- Float Type Flow Meter
- Rubber Liner Kit
- In Pond Lighting
- Upgrade to 4 Inch Gravity Flow System (Collector Box / Fish Safe Skimmer / 4 Inch Drains / 3-way Valve)
- Heater

Design Plans for the "Advantage 6000 Gallon Koi Pond"

Pond Shape



Formal



Semi-formal



Informal

The shape of a koi pond needs to meet two requirements. It has to be appealing to the eye and at the same time practical to maintain. Above you see three suggested shapes, formal, semiformal and informal. All three of these shapes can meet both requirements easily. They each have their own beauty. Some variation from these shapes in a 6000 gallon pond is acceptable but be careful. Don't design a "Puzzle" pond. Water circulation is very important in a "successful" pond. The water has to be able to circulate evenly without any dead areas. If you have any dead areas where the water doesn't move well debris will accumulate on the bottom and you will have to remove it by hand. Secondly, if there is a leaf within 100 yards of your pond it will end up in your pond. The jets will push it to the skimmer where it will be collected effortlessly if your pond is designed well. If you have a pond shaped like a piece of puzzle the leaves will never make it to the skimmer before they sink. Rather than trying to make a "very interesting" shaped pond, we would suggest you make a modestly shaped pond and make the surrounding landscape the eye catcher. A 6000 gallon pond should average approximately 10 feet wide, 17 feet long and 5 feet deep. Don't change the dimensions too much or you can adversely effect the function of the pond.

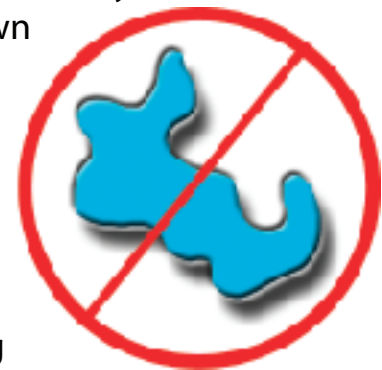

Design Plans for the "Advantage 6000 Gallon Koi Pond"

Pond Depth

3



Proper pond depth is extremely important. One of the most common mistakes made in building ponds today is that they are built too shallow. Often times you will see a koi pond with a net over the surface to prevent predators from eating the koi. This can easily be prevented by simply building the pond deeper in the first place. All sides should drop straight down at least 2 feet before starting to curve toward the drain area. This will make it almost impossible for a blue heron or raccoon to catch the koi. Blue herons are extremely effective if they can pin a fish to the bottom. The minimum 2 feet depth makes this impossible. Do not place any shelves on the side for plants. These shelves will create a feeding opportunity if less than 2 feet deep. Even with a deeper shelf, if you place a plant on the shelf and the top of the plant container is less than 2 feet deep herons will wait until the koi swim over the plant container and strike. If you must have plants in your pond, place the top of the plant containers either at water level or lower than 2 feet.

Another reason pond depth is important is to provide exercise for the koi. Koi get little to no exercise swimming horizontally. Only when they swim vertically, up and down, with the changing of water pressure back and forth do they get the exercise they need. Fish in a shallow pond become very sluggish. One last bonus of a deep pond is that it will hold a larger volume of water without taking up extra surface area. The larger the volume of water, the longer it takes for the temperature, ph, ammonia or nitrites to change. Koi don't like change. Make your pond at least 4 feet deep and your koi will love you for it.

As mentioned the depth is very important but so is the contour of the pond. After dropping down 2 feet begin to make a gentle contour toward the drain. If the drain is the lowest place on the bottom of the pond and all the sides gently flow toward it, the bottom of the pond will literally be "self cleaning". On the other hand, if you have sharp corners or flat areas on the pond bottom the debris will not be picked up by the bottom drain and will have to be removed by hand. Pay attention to the bottom contour and it will make your life easier.

Design Plans for the "Advantage 6000 Gallon Koi Pond"

Placement of Waterfall, Skimmer and Jets

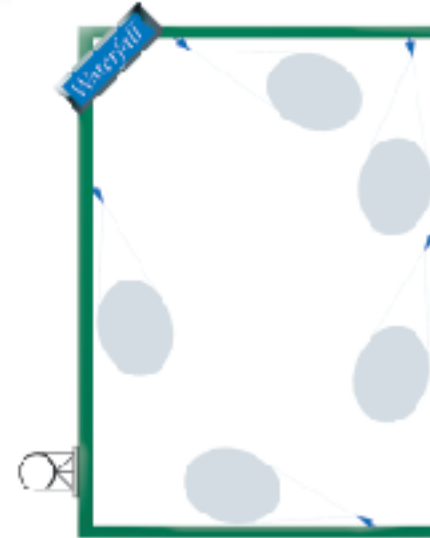
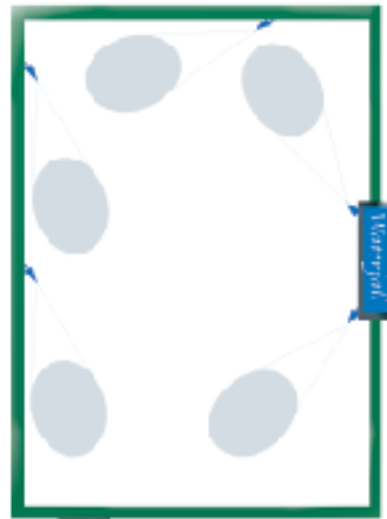
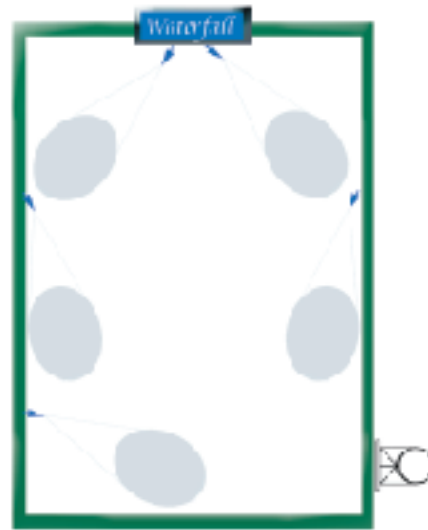

The placement of the waterfall dictates where the skimmer and jets should be installed. So first decide where the best location would be for the waterfall. Usually, the waterfall should be on the far side from where the pond will most often be viewed. This way those viewing the pond get a direct view of the waterfall flowing into the pond. Once the location of the waterfall is chosen, select the location for the skimmer and jets which best fits your pond. The above diagrams are designed so that the waterfall and jets all work together to direct leaves that land in the pond to the skimmer.

Note: The jets are extremely important to a successful pond. The jets not only assist in skimming leaves off the ponds surface but they also create a current for the fish to swim in and add considerable amounts of oxygen to the pond. **Don't build a pond without them.**

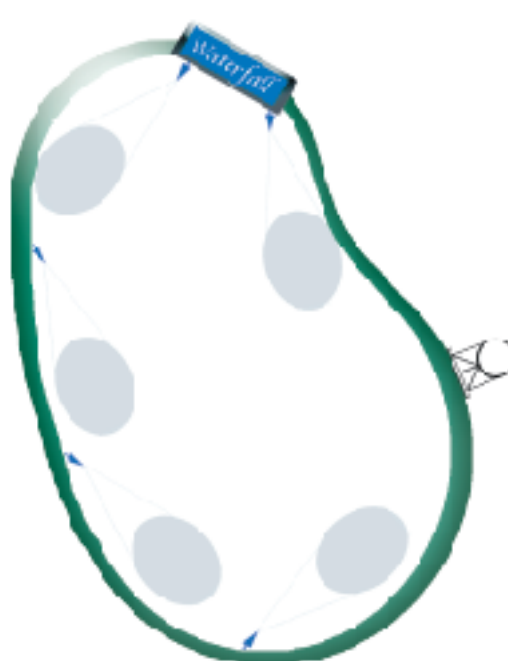

Design Plans for the "Advantage 6000 Gallon Koi Pond"

Pond Plumbing (with Standard Pressurized System)

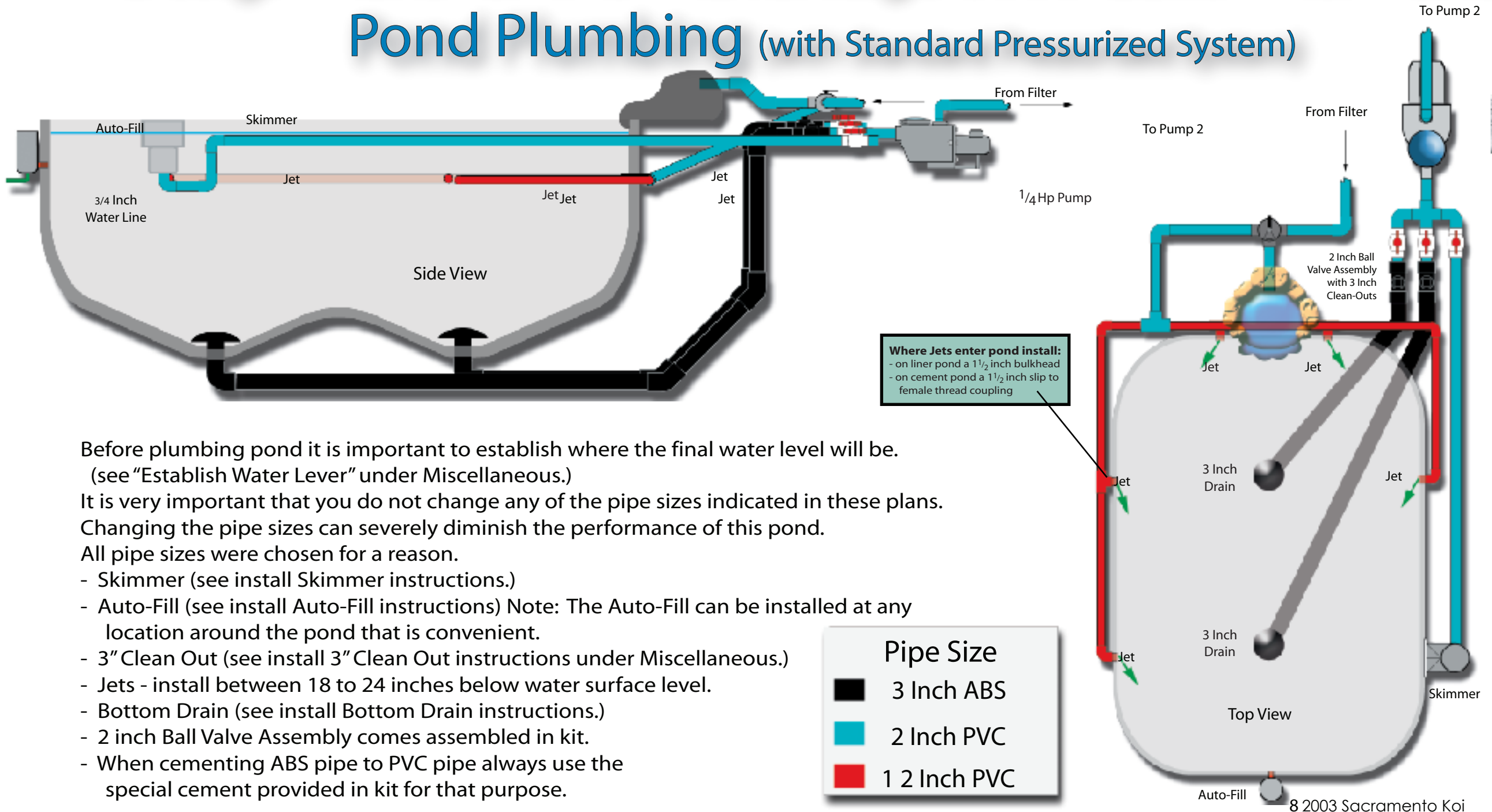



Before plumbing pond it is important to establish where the final water level will be.
(see "Establish Water Level" under Miscellaneous.)

It is very important that you do not change any of the pipe sizes indicated in these plans.
Changing the pipe sizes can severely diminish the performance of this pond.

All pipe sizes were chosen for a reason.

- Skimmer (see install Skimmer instructions.)
- Auto-Fill (see install Auto-Fill instructions) Note: The Auto-Fill can be installed at any location around the pond that is convenient.
- 3" Clean Out (see install 3" Clean Out instructions under Miscellaneous.)
- Jets - install between 18 to 24 inches below water surface level.
- Bottom Drain (see install Bottom Drain instructions.)
- 2 inch Ball Valve Assembly comes assembled in kit.
- When cementing ABS pipe to PVC pipe always use the special cement provided in kit for that purpose.

Pipe Size	
	3 Inch ABS
	2 Inch PVC
	1 2 Inch PVC

Design Plans for the "Advantage 6000 Gallon Koi Pond"

Pond Plumbing (with optional 4 inch drain and gravity fed pre-filter)

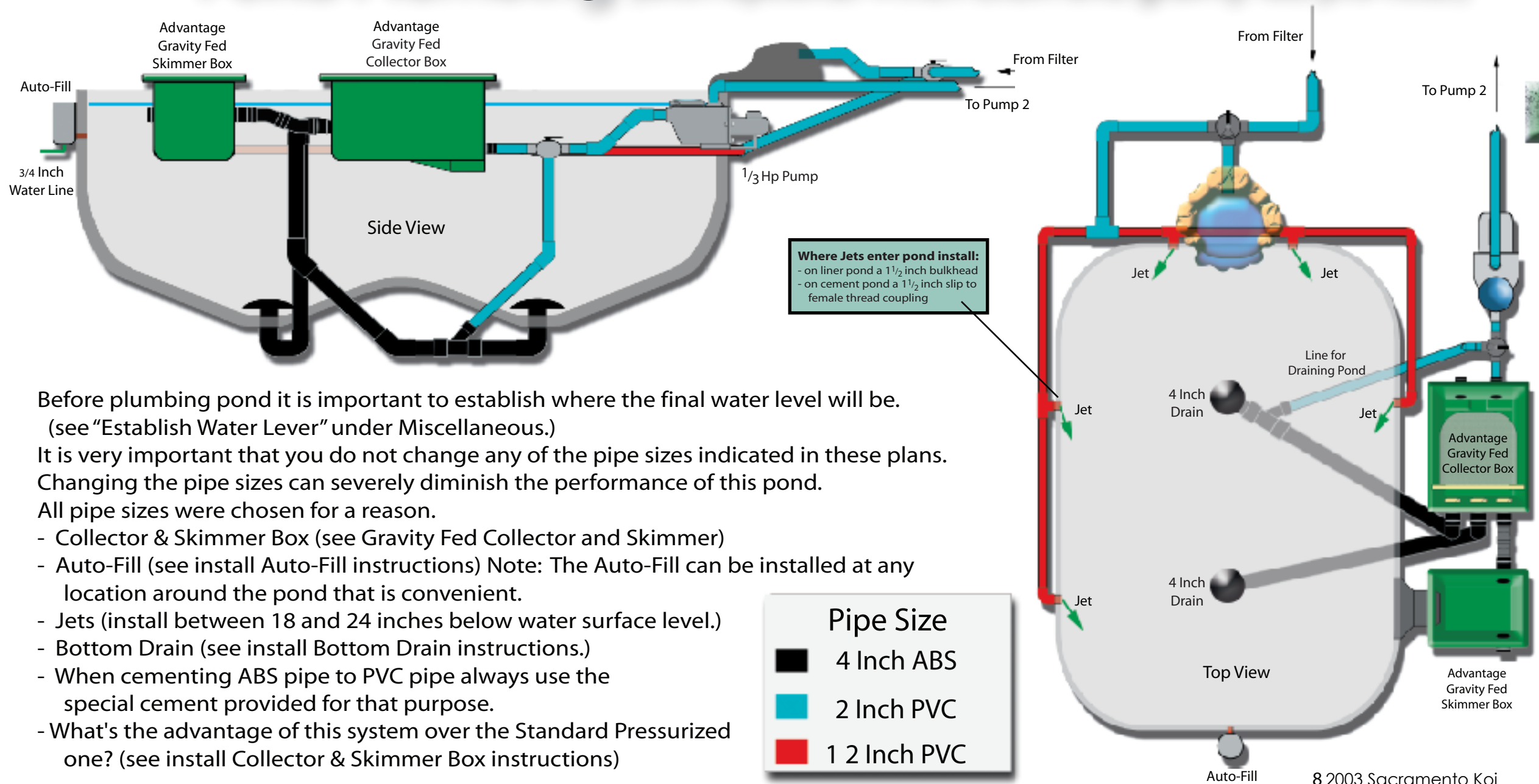

Before plumbing pond it is important to establish where the final water level will be.
(see "Establish Water Lever" under Miscellaneous.)

It is very important that you do not change any of the pipe sizes indicated in these plans.
Changing the pipe sizes can severely diminish the performance of this pond.

All pipe sizes were chosen for a reason.

- Collector & Skimmer Box (see Gravity Fed Collector and Skimmer)
- Auto-Fill (see install Auto-Fill instructions) Note: The Auto-Fill can be installed at any location around the pond that is convenient.
- Jets (install between 18 and 24 inches below water surface level.)
- Bottom Drain (see install Bottom Drain instructions.)
- When cementing ABS pipe to PVC pipe always use the special cement provided for that purpose.
- What's the advantage of this system over the Standard Pressurized one? (see install Collector & Skimmer Box instructions)

Design Plans for the "Advantage 6000 Gallon Koi Pond"

Filter Setup

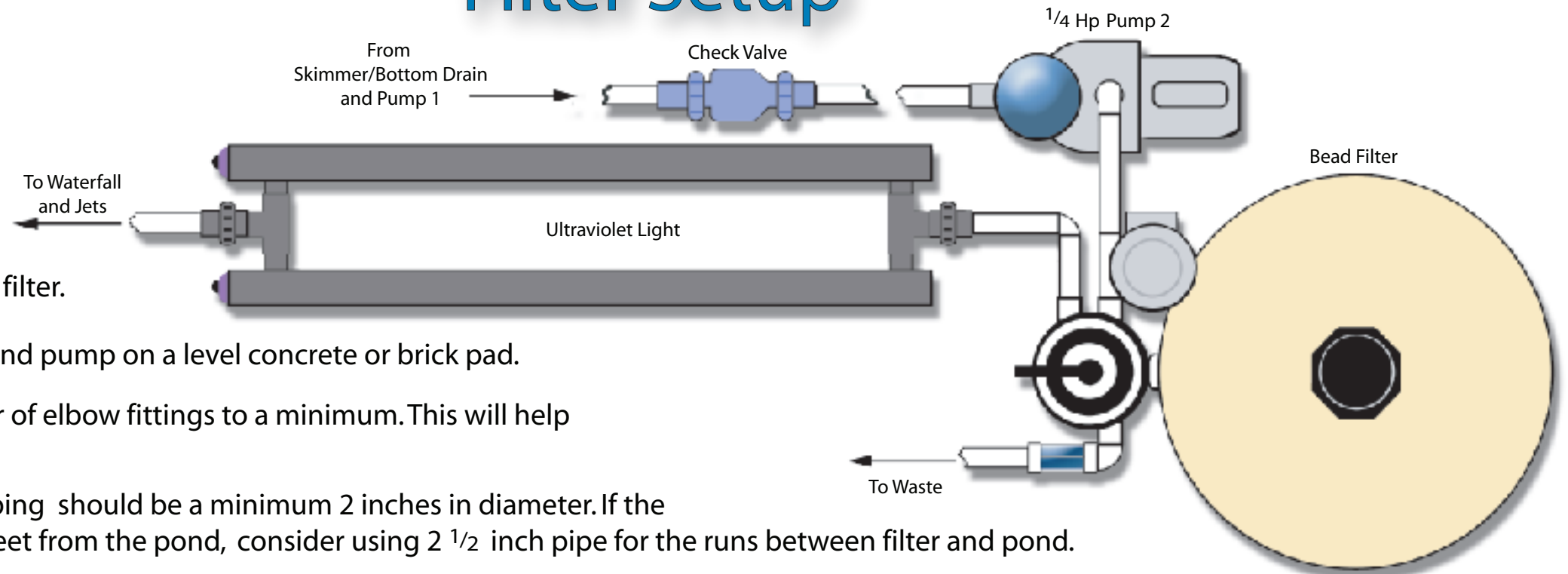

This is one suggestion of how to lay out plumbing for the filter.

If possible, place filter and pump on a level concrete or brick pad.

Try to keep the number of elbow fittings to a minimum. This will help with the water flow.

All pipe used for plumbing should be a minimum 2 inches in diameter. If the filter is further than 75 feet from the pond, consider using 2 1/2 inch pipe for the runs between filter and pond.

Resist stubbing pipes up through concrete pad. It looks great but severely reduces your options if in the future you decide to change something.

The 2 inch check valve should be placed between the pump and the pond. If the pump is above the water level of the pond, the closer the valve is installed to the pond, the easier it will be to prime the pump. (see "Pump Placement" under "Miscellaneous")

See "Ultraviolet Light Installation" before plumbing UV light in place.

The Advantage of using two pumps in series rather than one larger pump is two fold:

- 1) Two 1/4 Hp pumps in series will push more water with less amps than one 3/4 Hp pump.
- 2) When placed on separate circuits, if one pump fails the other will still keep some water flowing until the other pump can be repaired.

The "waste line" will dump between 40 and 50 gallons in approximately 60 seconds each time the filter is back washed. If the waste line is attached to a sewer line or rain down spout drain make sure it can support that amount of water flow. Do not restrict the flow from the waste line as this will reduce the effectiveness of the backwash cycle.

Design Plans for the "Advantage 6000 Gallon Koi Pond" Filter Setup (with optional Glass Polishing Filter)

This is one suggestion of how to lay out plumbing for the filter.

If possible, place filter and pump on a level concrete or brick pad.

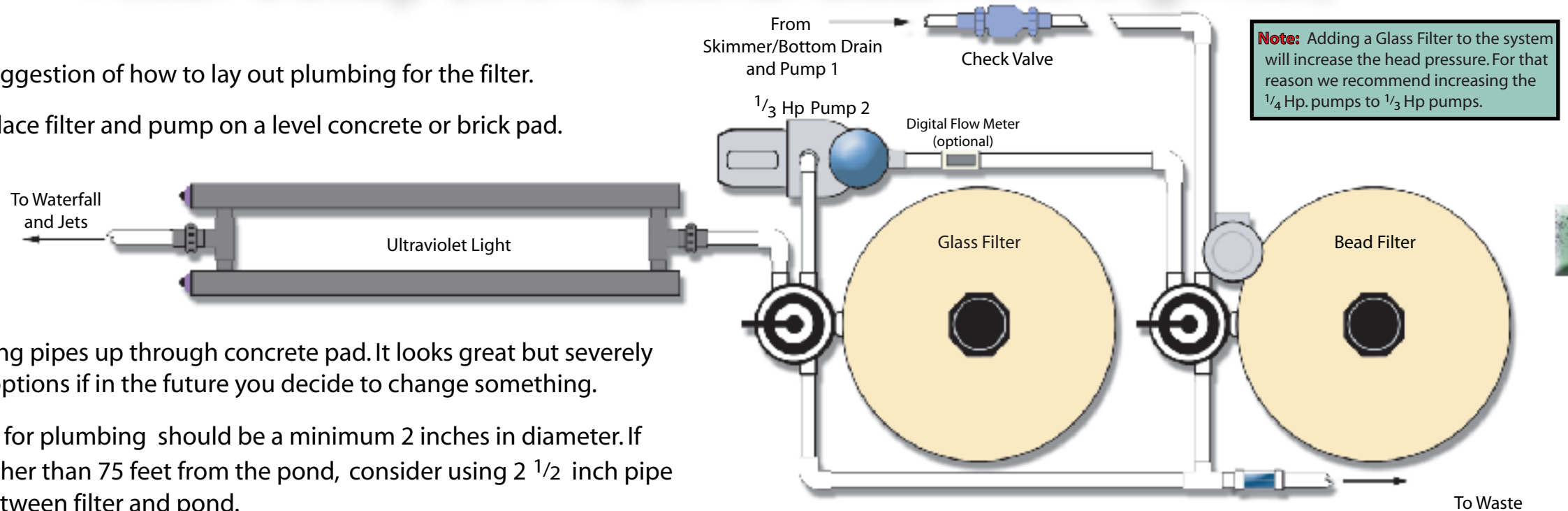

Resist stubbing pipes up through concrete pad. It looks great but severely reduces your options if in the future you decide to change something.

All pipe used for plumbing should be a minimum 2 inches in diameter. If the filter is further than 75 feet from the pond, consider using 2 1/2 inch pipe for the runs between filter and pond.

Try to keep the number of elbow fittings to a minimum. This will help with the water flow.

See Ultraviolet Light Installation before plumbing UV light in place.

The Advantage of using two pumps in series rather than one larger pump is two fold:

- 1) Two 1/3 Hp pumps in series will push more water with less amps than a 1 Hp pump.
- 2) When placed on separate circuits, if one pump fails the other will still keep some water flowing until the other pump can be repaired.

Plumb both waste lines together with one sight glass "down stream" from where they join together.

With this plumbing setup, one blower can be used to backwash both filters. The "waste line" will dump between 40 and 50 gallons in approximately 60 seconds each time the filter is back washed. If the waste line is attached to a sewer line or rain down spout drain make sure it can support that amount of water flow. Do not restrict the flow from the waste line as this will reduce the effectiveness of the backwash cycle.

Design Plans for the "Advantage 6000 Gallon Koi Pond"

Ultraviolet Light Installation

The "Advantage 6000 System" comes with an Emperor Aquatics (model 2130) 130 watt Ultraviolet light with 2 inch unions. The manufacturer optimal recommended flow rate is 3420 gph (57.0 gpm). The average "Advantage 6000 System" flow is approximately 3300 gph (55 gpm) depending on height of waterfall. Therefore, all the water flowing from the filter can be directed through the UV light.



Important: The Emperor 130 watt UV light should be installed with both bulbs laying side by side rather than one above the other. This will prevent air from being trapped inside the units. Also keep in mind that the bulbs will need to be changed once a year so when installing the unit, allow enough room so the bulb can be removed.

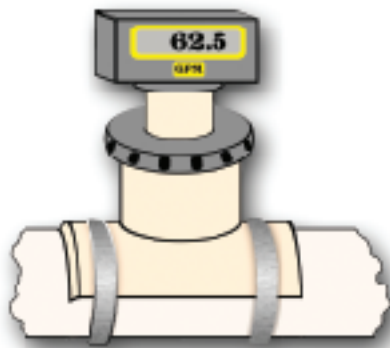

Optional Digital Flow Meter

Use of a Digital Flow Meter is the most accurate way of measuring the amount of water flowing through the filter system at any one time. There are several advantages of being able to accurately measure the water flow in the system. One is that you can tell when to backwash the filter by how much the water flow has slowed down. Another advantage is after back washing the filter you can verify the filter is clean by checking to make sure the flow has returned to normal. Always install meter after filter. This will prevent any solid waste from causing the paddle wheel to stick.

Design Plans for the "Advantage 6000 Gallon Koi Pond" Bottom Drain Installation

Liner Pond:

- 1) Plumb the bottom drain flush with bottom of the pond.
- 2) Pour cement around base of drain and finish smooth. This will prevent the drain from moving if the pond is ever drained and the surrounding water table is higher than bottom of pond.
- 3) Place liner in pond. Make sure liner is long enough to reach up and over all sides.
- 4) Cut a 2 inch hole in liner over drain.
- 5) Reach inside and make sure no debris is between the drain and the liner.
- 6) Place a line of silicone caulk between the drain and the liner.
- 7) Smooth liner onto drain and screw down top base.
- 8) Cut the rest of the liner out of the center of the drain opening.
- 9) On 3 Inch drain fill top cap with sand and install top cap plug.
- 10) Install top cap on drain.

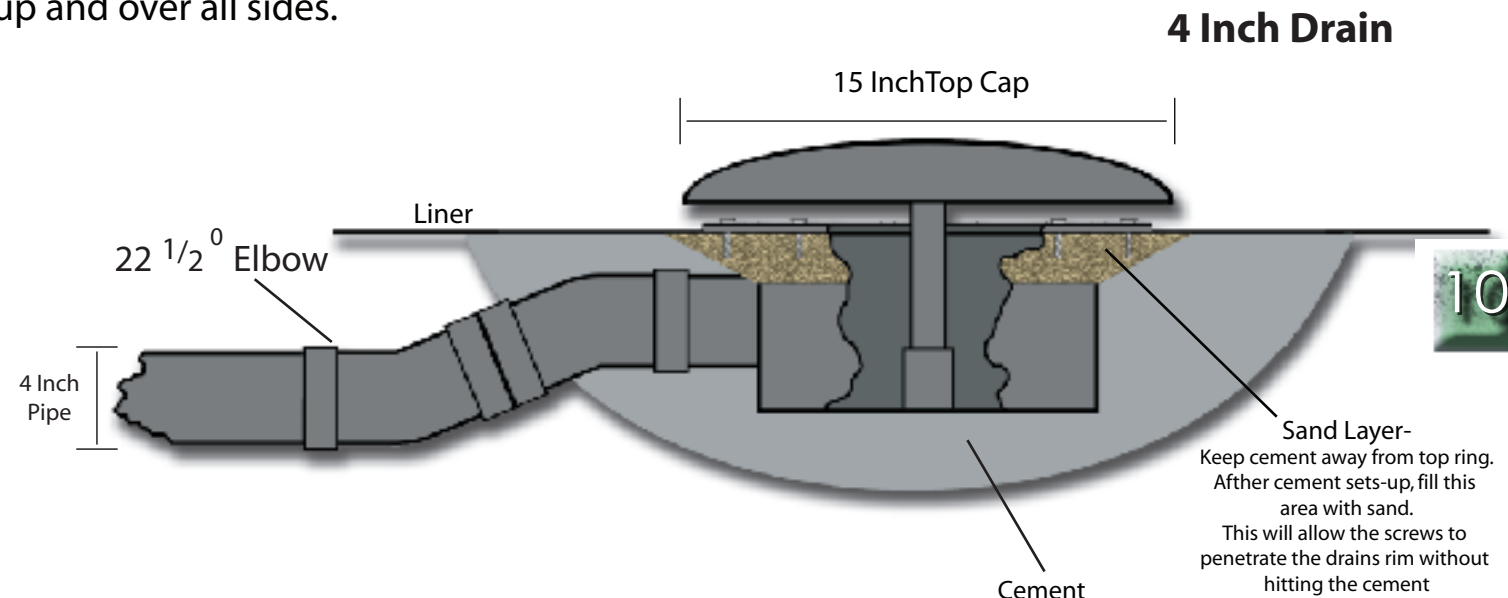
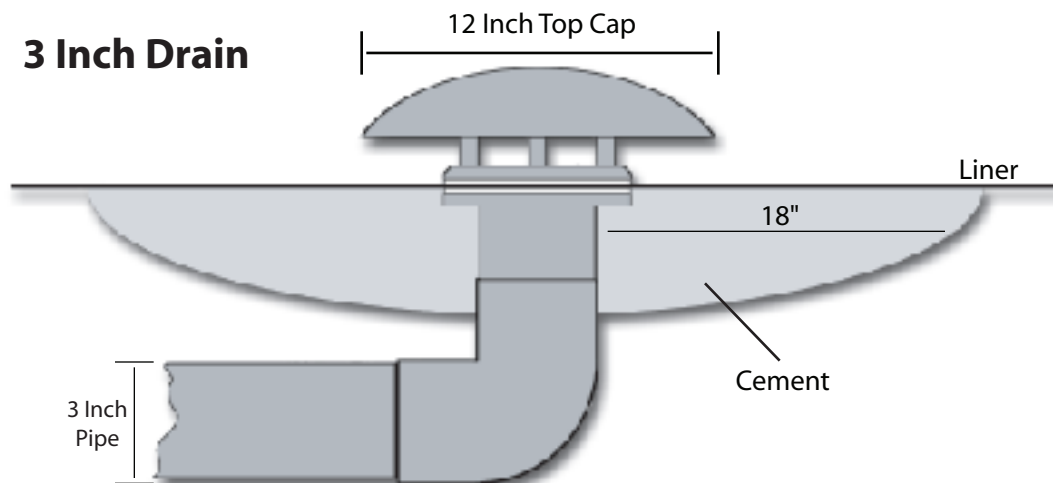

Concrete Pond:

- 1) Plumb the bottom drain so that it will be flush with bottom of the pond once the concrete is poured.
- 2) Make sure all screws are installed. If the screws are not installed when cement is poured, cement will fill the screw threads.
- 3) On 3 Inch drain, once cement is finished, fill top cap with sand and install top cap plug.
- 4) Install top cap on drain.

Design Plans for the "Advantage 6000 Gallon Koi Pond" Skimmer Installation

All the Advantage Koi Pond Systems include "circular weir" type skimmers which are safer for fish than the "flap weir" type skimmers.

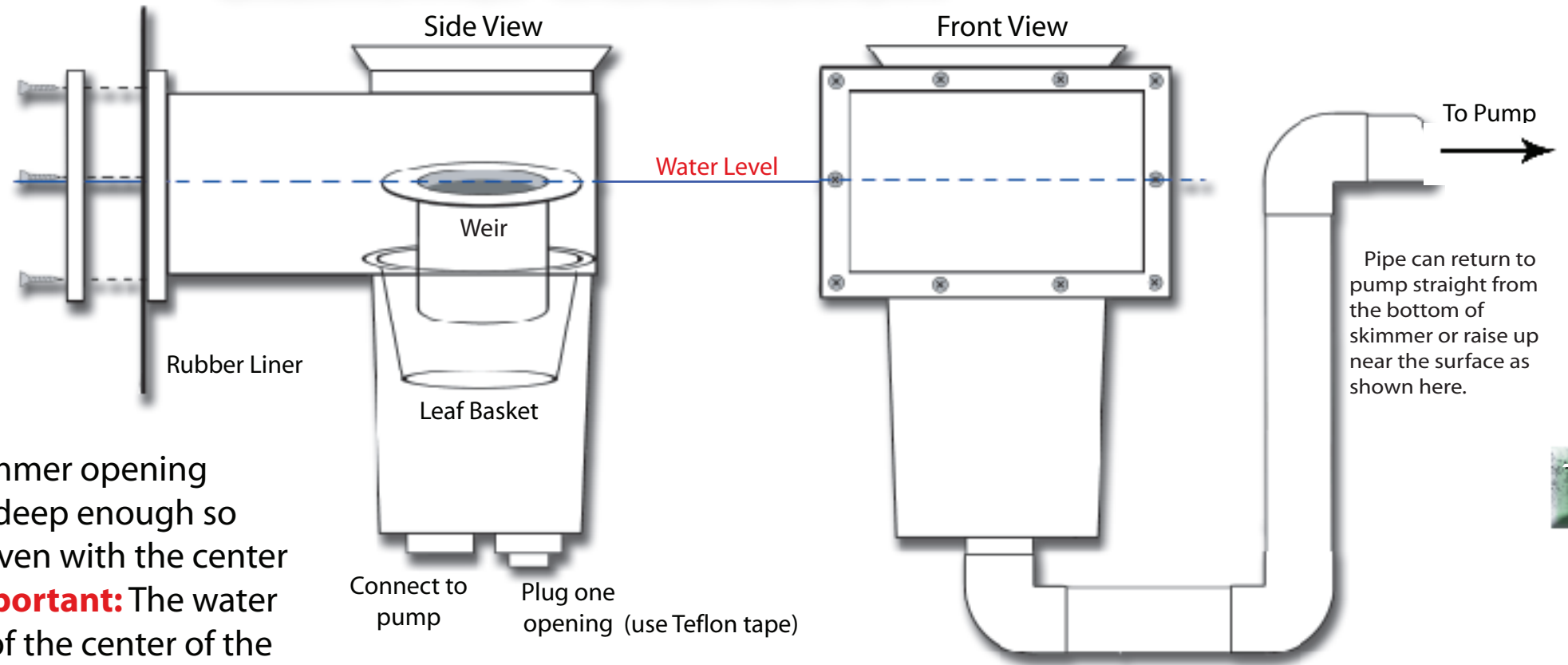

1) Dig out area and place skimmer opening flush with side of pond and deep enough so that the water level will be even with the center of the skimmer opening. **Important:** The water level must be within 1 inch of the center of the skimmer opening or the skimmer will not function properly.

2) Plumb skimmer with 2 inch pipe to the "2 inch ball-valve assembly" connected to the pump. (see "Filter Setup")

3) Concrete Ponds- Anchor to rebar to hold in proper position during concrete pour.

4) Rubber Liner Ponds- Fill hole around skimmer with concrete to prevent it from moving.

5) Rubber Liner Ponds- When installing liner, bring liner over opening of skimmer. Fill pond with water to a level just below skimmer. Smooth liner over face of skimmer and screw on face rim. Then, cut liner out from center of skimmer opening.

Important Note: When Installing the skimmer make sure the top opening is level in all directions so that the weir will float up and down freely.

Design Plans for the "Advantage 6000 Gallon Koi Pond"

Gravity Fed Collector Box and Skimmer

The Advantage Collector Box is extremely effective on bigger ponds in removing large amounts of leaves and waste from the pond. In situations where a normal skimmer basket would fill up in less that one day, the Collector Box can be a real solution.

Advantages of The Collector Box

- 1) Large net able to hold huge amount of leaves, fish waste and debris.
- 2) Very easy to clean. Just dump net.
- 3) Separate slide valves on each 4 inch inlet allows you to controll the water flow and on occasion, close off all but one valve to thoroughly flush out each drain line.
- 4) Gently collects out fish waste before it goes through the pumps, thus redusing the load on the filter bacteria.

Advantage of The Skimmer Box

- 1) Extremely effective at skimming off debris from the ponds surface.
- 2) Totally fish safe gravity fed passive system.
- 3) Nothing to clean. Debris goes directly into Collector Box net

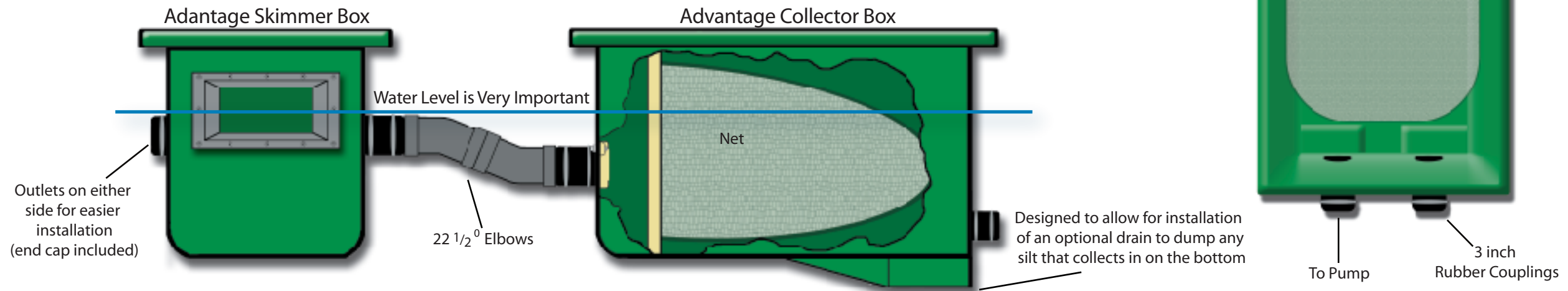

Design Plans for the "Advantage 6000 Gallon Koi Pond"

Installation of Bulkhead Fittings in Liner Pond

Bulkhead fittings are used anytime it is necessary for a pipe to pass through a rubber liner. They are relatively simple to install and when installed properly are very reliable. The following procedure should be followed when installing Jets in a liner pond.

- 1) Bulkhead fittings should be plumbed into the pond wall so that the face of the fitting is flush with the side of the pond. (see below)
- 2) Place the rubber liner in the pond and "Set the Bottom Drain". (see installation of Bottom Drain)
- 3) Fill the pond with water to just below the bulkhead fittings. As you fill the pond spread the liner out evenly so that no large folds exist. Several small folds are much better than one large fold.
- 4) Spread liner evenly over the face of the bulkhead fitting. Place cover plate against face and rotate until plate "locks in place" with grooves in fitting.
- 5) Install 4 screws to secure plate. This will create a water tight seal with the liner.
- 6) Cut liner out of the center of the bulkhead fitting.

Example of how to plumb bulkhead fittings for a liner pond when using jets.

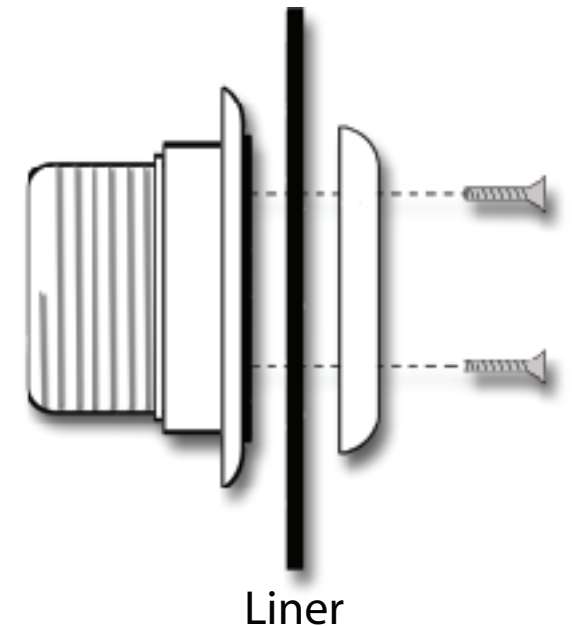
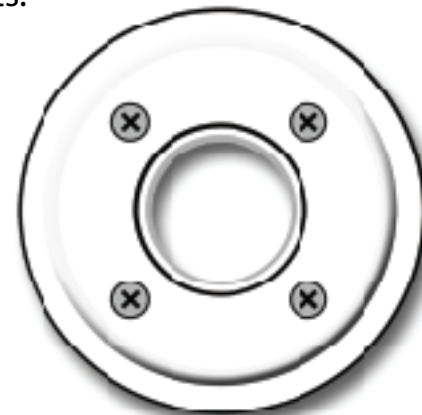
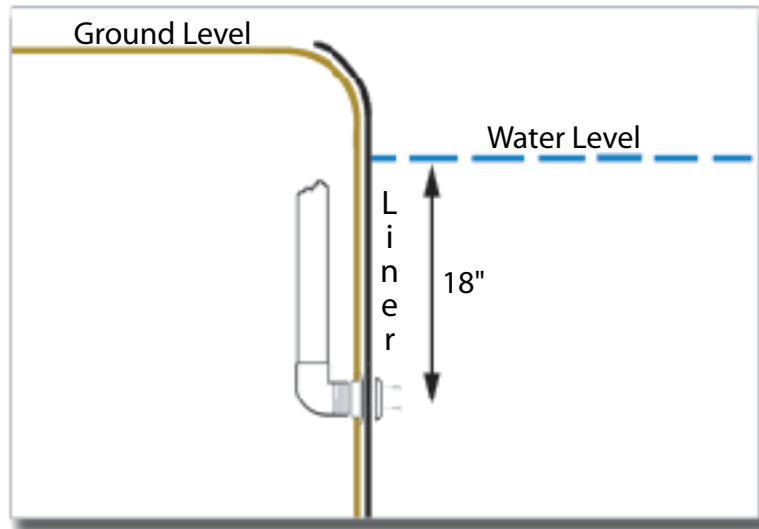

Design Plans for the "Advantage 6000 Gallon Koi Pond"

Rock Work Around Edge of Pond

For Concrete Pond

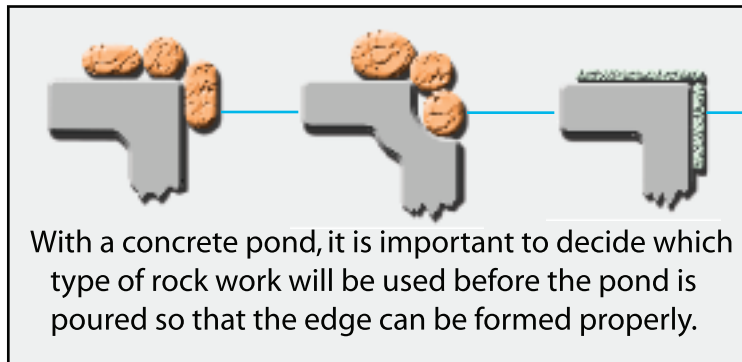

For Liner Pond

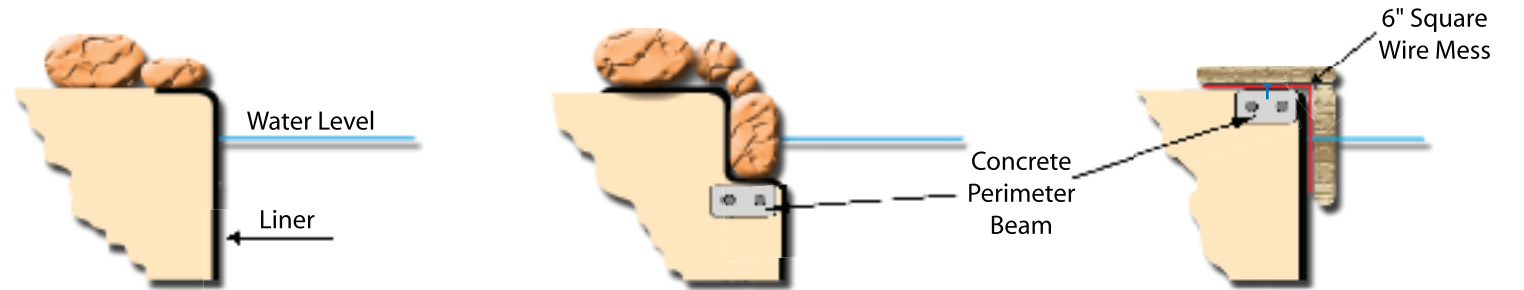

A) This style is the easiest to build but should not be used unless dirt around pond is very stable otherwise edges could cave in toward pond. This style is also less attractive than "B" or "C" because liner is visible

B) This style takes more effort to build but gives a very esthetic look because the liner is not visible. When algae forms on the rocks and liner below the water level, it gives the illusion that the rocks continue deep into the pond.

C) This style works very well with flat rock such as flagstone. Fill pond first with water to stretch out liner, then contact cement liner to concrete beam and cut off excess. Anchor wire mesh to top of beam with a molly bolt. The wire mesh will support the rock when mortaring over the liner.

Concrete Perimeter Beam



For a liner pond we highly recommend a concrete beam be poured around the pond to stabilize edges of pond. Make sure to set and plumb the skimmer in place before pouring the concrete beam.

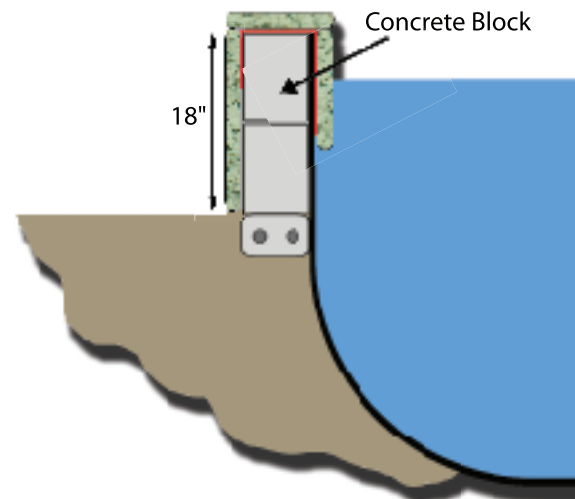

Raised Ponds

A raised pond has several advantages over one built at ground level:

- Do not need to dig pond as deep.
- Provides an area to sit on when viewing fish.
- Less likely children will fall into pond.

Design Plans for the "Advantage 6000 Gallon Koi Pond" Waterfalls

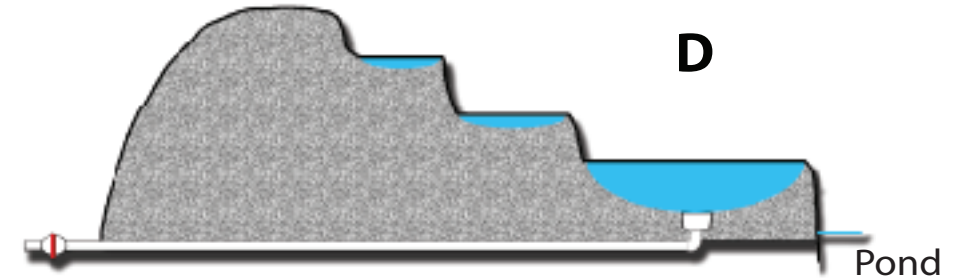
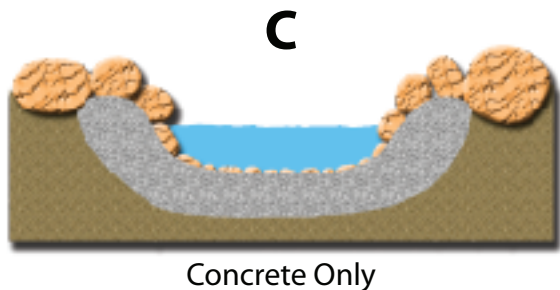
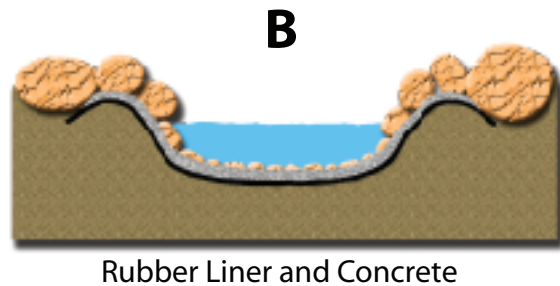
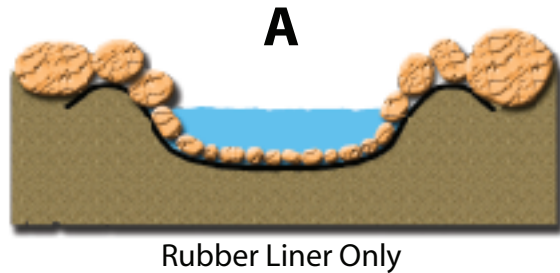

Whole books have been written about building waterfalls. The following are just some basic hints on things to consider when building one.

1) Do not make falls to high.

- Too much noise. Gurgling water is very pleasant to listen to, whereas Niagara Falls will give you a headache. Beware, often times people who build very large waterfalls after a while look for some way to turn them down.
- Disturbs water surface. The purpose of the pond is to enjoy the fish. If you can't see the fish it defeats the purpose of the pond.
- Adds to the head pressure. A higher waterfall will require a larger pump which will use more energy.

2) **Consider sheeting water.** Water sheeting over rocks is very attractive and creates less noise. It is easy to accomplish by simply mortaring in place a flat rock with the use of a level at the top of each of the falls you want to sheet.

3) **When building a stream.** Resist simply laying down a rubber liner and covering it with rocks. (see example **A**) It looks nice for the first six months but then leaves and debris will accumulate in the rocks and begin to decay, turning the water a "root beer" color. The only way to cure this is by literally removing the rocks and washing off the liner.

A much better way to build a stream is shown in example **B**. The only difference between A and B is that over the rubber liner you pour a 2 inch layer of cement and then cover that with a layer of stones that are pushed half way down into the cement. After the cement begins to "set up" gently spray off the excess cement on the surfaces of the rocks. This should leave the rocks clean and yet still halfway embedded in the cement. The result is that now, leaves and debris can not get under the rocks and can easily be washed away. The last example **C** works well on shorter streams but is prone to cracking on long streams.

A nice trick in building a stream that leads into the pond is to create a slightly deeper area just before it enters the pond. Place a drain in the bottom of this area. (see example **D**) Then when you need to clean the stream, simply turn off the pump, open the drain and wash everything down into the drain. This prevents the debris from being washed into the pond.

Design Plans for the "Advantage 6000 Gallon Koi Pond"

Auto Fill and Jets

Automatic Filler Installation

The automatic filler should be installed as near to the pond as possible and yet in an area where it is least visible. Automatic fillers require little to no maintenance. To properly plumb the unit requires an 1 1/2 inch pipe be extended straight into the pond 7 1/2 inches below the pond water level so that the "overflow outlet" will be 1 inch above the same water level. Connect a 3/4 inch fresh water line to the bottom of the unit. Flush the fresh water line well before installing valve assembly in unit.

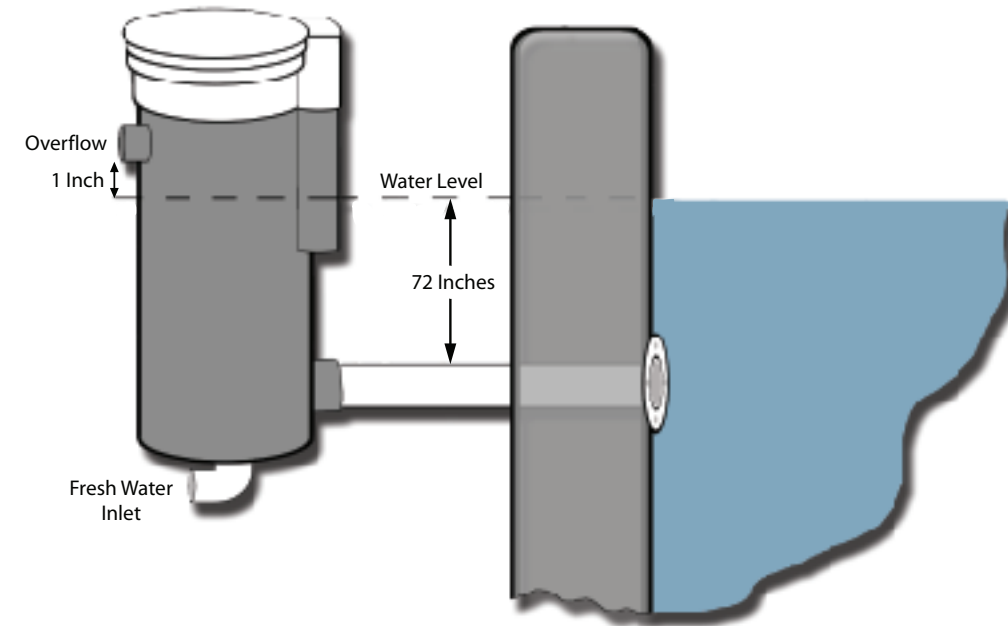
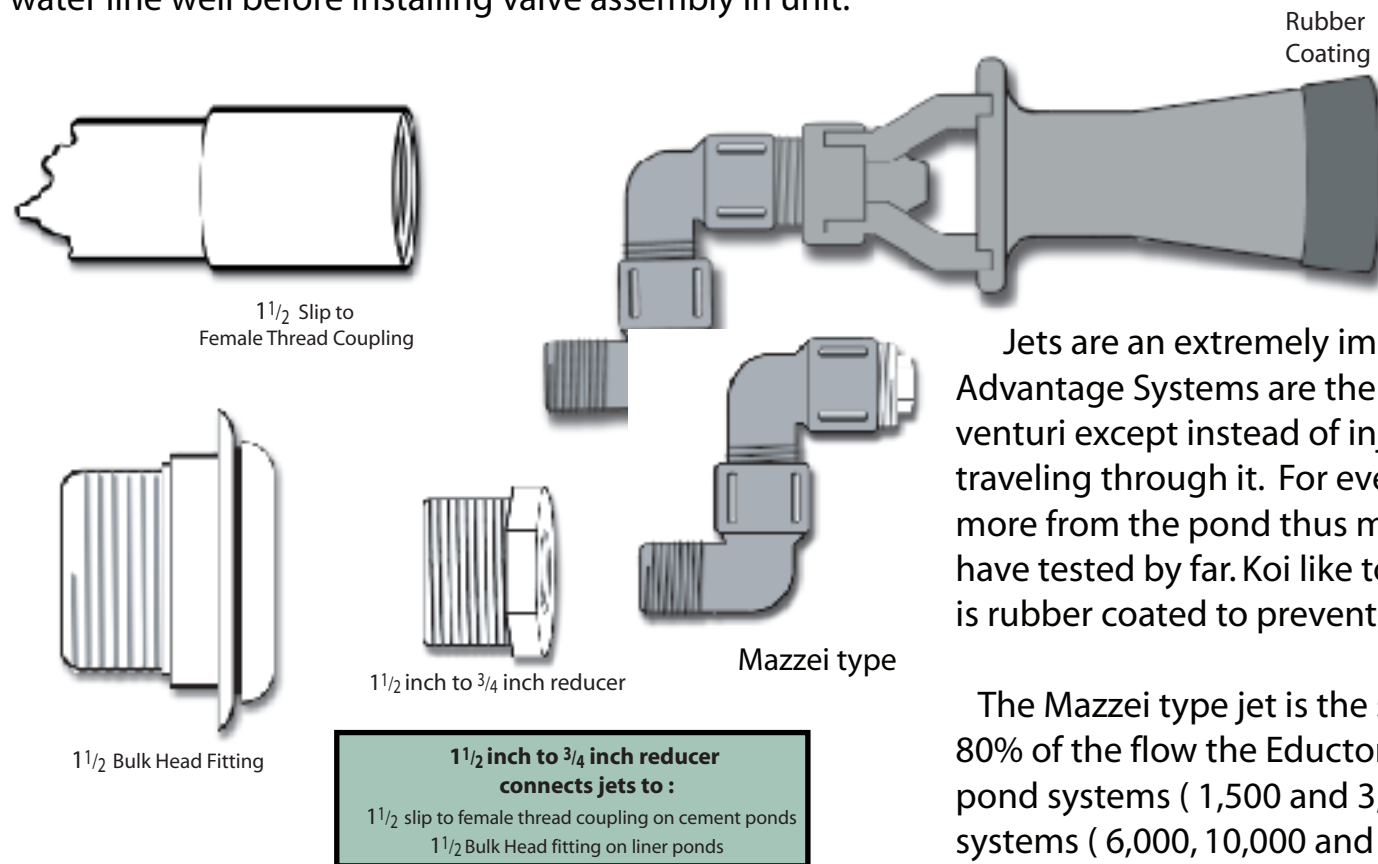

Jets

Jets are an extremely important part of a successful pond. For this reason the two jets used in Advantage Systems are the Mazzei type and the Eductor type. The Eductor type jet works like a venturi except instead of injecting air into the water it simple adds more water to the water traveling through it. For every one gallon of water pumped through the Eductor, it gathers four more from the pond thus moving a total of five gallons. The Eductor is the most efficient jet we have tested by far. Koi like to swim into the current created by the jets so the end of each Eductor is rubber coated to prevent the koi from being injured.

The Mazzei type jet is the second most efficient jet we have tested. It produces approximately 80% of the flow the Eductor does but is much smaller in size. For this reason, the two smaller pond systems (1,500 and 3,000) come standard with the Mazzei type jets while the three larger systems (6,000, 10,000 and 15,000) require the Eductor Type.

Design Plans for the "Advantage 6000 Gallon Koi Pond" Miscellaneous

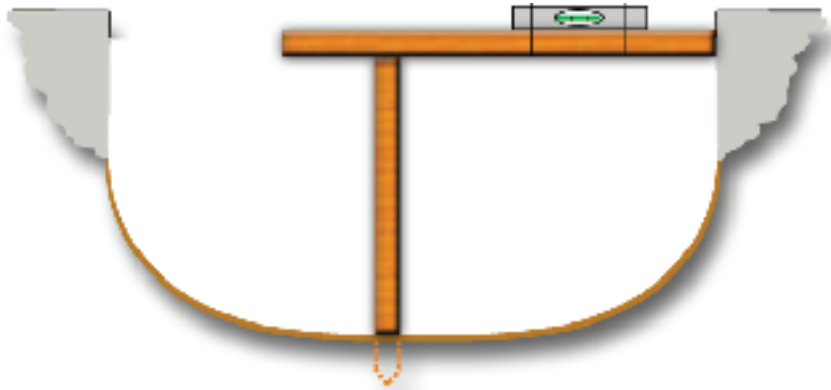

Establishing Water Level

After pond has been excavated and the general contour is established you will need to establish where the water level will be in order to set the skimmer and check the overall depth of the pond. This can easily be done by first pounding a stake in the center of the pond to the height that the water level will be. Then take a board, with a level taped to it, and place it on top of the stake. With this you can mark, with spray paint, around the pond where the water level will be.

Installing 3" Clean Out

At the point where the 3 inch pipe from the bottom drain is reduced to 2 inch pipe, install the 3 inch clean out. If any debris collects in the line at this point, it can easily be removed without cutting any pipe. Important: Do not use regular PVC glue when cementing PVC to ABS pipe. Use the special glue provided in kit for that purpose. Also, seal the top cap on the clean out with Teflon tape to prevent any air leaking which could cause problems when priming the pump.

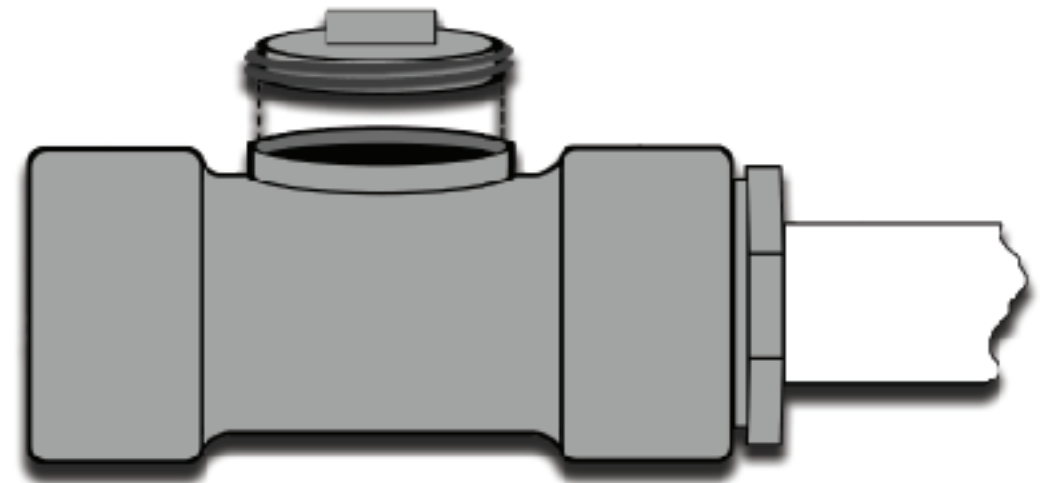

Pump Placement

All the pumps used in the "Advantage Systems" are the self priming type. This means they can be installed up to 36 inches above the water level if necessary without losing much efficiency. The pumps perform best when installed at or near the water level. If the pump needs to be installed below the water level a shut off valve should be installed between the pump and the pond to prevent the water from overflowing when it is necessary to open the leaf trap for cleaning. Also, when the pump is installed below the water level it is best to install the check valve between the pump and the filter rather than between the pump and the pond.

Design Plans for the "Advantage 6000 Gallon Koi Pond"

Electrical Setup

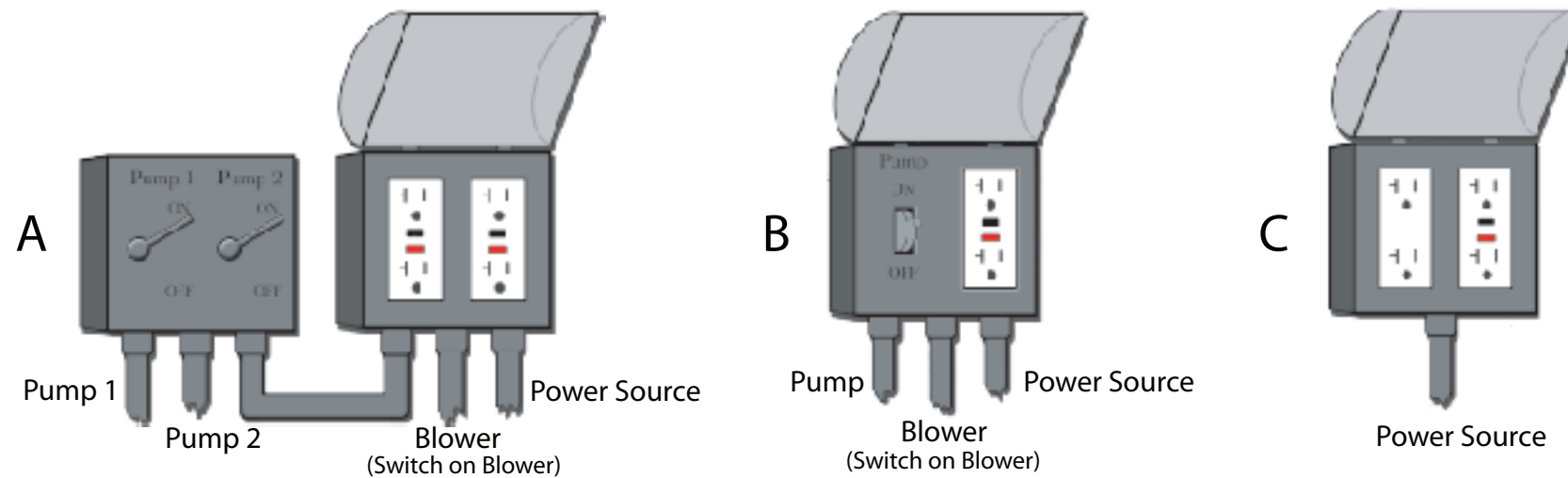

Helpful Hint: Is it less expensive to run a pump at 220v rather than 110v?

Power companies charge for electricity based on kilowatts per hour. To calculate the expense to operate a pump just multiply the amps times the volts. This will tell how many kilowatts the pump will draw.

Formula: (Amps x Volts = Watts)

Example: (4.5 amps x 220 volts = 990 watts or .990 kilowatts)

(9.0 amps x 110 volts = 990 watts or .990 kilowatts)

Conclusion: The electricity cost to run a pump at 220 or 110 is the same.

It is highly recommended that all electrical work be done by a licensed electrician and according to local codes. The following are only suggestions for your electrician as to how to set up the electrical for the filter system. Keep in mind the following:

- 1) Typically a dedicated 20 amp circuit is more than sufficient to operate the system
- 2) A "Ground Fault Circuit Interrupter" or GFCI switch is extremely important in any electrical circuit used near water. The GFCI is designed to disconnect the electricity instantly if there is ever a fault to ground. This could save both your life and the life of your fish. If the circuit already is protected with a GFCI it is not necessary to add an additional one.
- 3) The switches should be located close to the valve of the filter for convenience when back washing.
- 4) The Ultraviolet light needs to be plugged in. Cutting off the plug to hard wire light voids manufacturers warranty.

The filter will need to be back washed on a regular basis, typically once a week. Back washing the filter requires turning off and on both the pump and blower in a certain sequence. Setting up the electrical properly can make the process both easier and safer. All three wiring examples have both advantages and disadvantages.

Example A: Takes a little more effort to set up but has the advantage of having both switches for the pump and the blower close together plus you don't have to open and close the water proof cover each time. Place each pump on a separate GFCI switch and circuit breaker, so that if one fails it will not trip the other pump.

Example B: Slightly easier to set up but the weather proof cover needs to be opened each time. - Both pumps are on one circuit and switch

Example C: This, although the easiest to set up, would probably be the least desirable because it would require not only plugging and unplugging both the pump and blower each time but also requires opening and closing the weather proof cover.

Design Plans for the "Advantage 6000 Gallon Koi Pond"

Optional Light Installation

Lights in a koi pond add a whole new dimension because the enjoyment of a beautiful pond dose not have to end at nightfall. To achieve a well lit pond the quantity and placement of the lights is critical. A single light added to a pond is nice but it will also create a lot of shadows. With several lights, at different angles, shadows are reduced significantly and the koi show up much better. Lights should be placed along the wall of the pond closest to the viewing area so that the pond and koi are lit up from that angle.

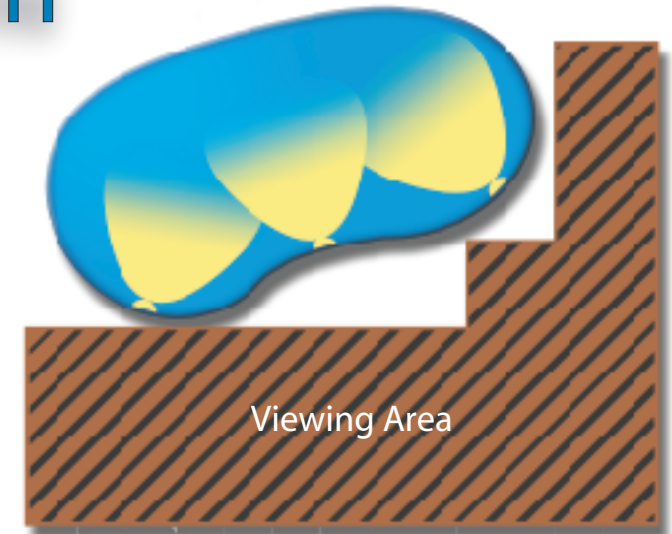

Example of light placement

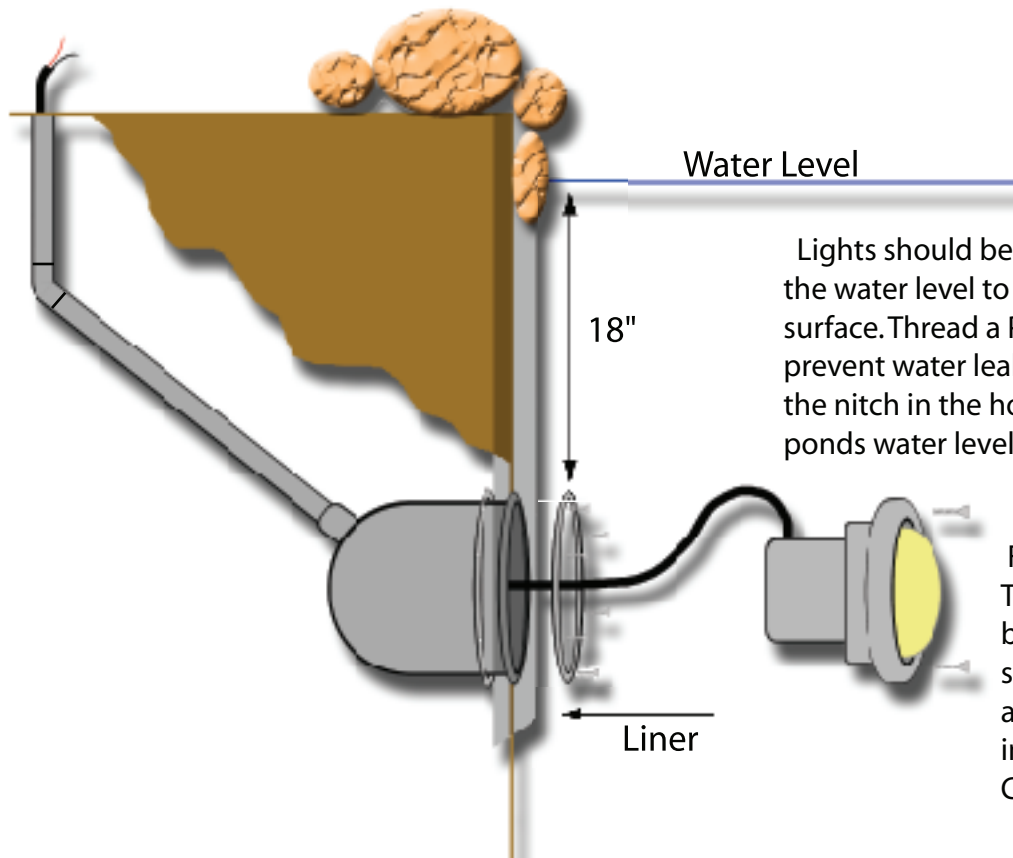

Lights should be installed during the plumbing stage of the pond construction. Dig a hole in the side of the pond 18 inches below the water level to accommodate the metal niche for the light. Dig a 3" wide trench down behind the metal niche angling toward the surface. Thread a PVC 3/4" slip to male thread pipe coupling into the rear of the metal niche. Make sure to Teflon tape the threads to prevent water leakage. For liner ponds place the brass support ring that the liner cover ring screws into on the niche first. Then place the niche in the hole dug for it and carefully glue a 3/4" PVC pipe into the back of the niche. Make sure PVC pipe extends above the ponds water level. Repack dirt around the 3/4" pipe. The face of the metal niche should be level with the side of the pond.

For liner ponds: After the liner is installed and water is being added, stop filling just before water reaches the niche. This will make sure liner is stretched thoroughly. Place the liner ring over the surface of the niche and screw ring to brass backing ring compressing the liner between the rings. Cut the liner out of the center area of the niche. This should create a water tight seal around the niche. Next, string the cord from the halogen light through the niche and 3/4" pipe. Leave approximately 20" of extra cord at the light end. Wind this extra cord around the light and then install light into niche. This extra cord will allow you to change the light bulb without lowering the water level. Connect the end of the cord to the proper voltage power supply.